

- Stainless steel latchbolt which springs 13mm into the gate post and then moves 30mm when the key is turned to deadlock the lock.
- Latchbolt is adjustable in length for precise fitting on site.
- Easy to rotate latchbolt for LH/RH gates.
- Supplied with handles – three styles available.
- Supplied with bolt guide plate and gate post strike plate .



PRODUCT OPTIONS

- Two locks available,
- SBLD1601** to fit flat bar and up to 30mm box section
 - SBLD1602** to fit 40mm to 60mm box section

- Two styles of handle available
- TDH** Traditional handle set
 - AH** Black lever handle set



INSTALLATION

- Drill 2 x 9mm dia. holes at 92mm centres for M8 fixing bolts.
- Drill 18mm clearance hole for latchbolt at 22mm centres down from the top 9mm hole.
- Fix lock in place using stainless steel clamp plate, bolt support plate and 2 stainless steel countersunk fixing bolts supplied.
- Drill clearance hole in keep or outer frame to receive the latchbolt. Slot this hole vertically to allow for gate sag.
- Ensure latchbolt moves freely without binding on gate or frame.

MAINTENANCE

- Every 2 months - Lubricate latchbolt with light oil.
Annually – Dismantle lock and spray mechanism inside with light oil.

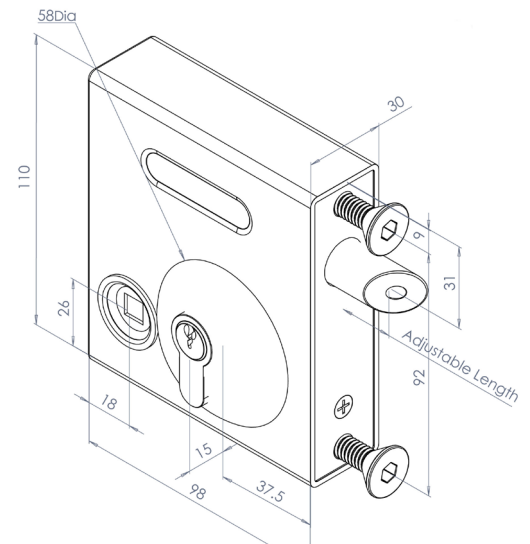

VISIT GATEMASTERLOCKS.COM FOR MORE INFORMATION

