

AUTO-LOCKING DROP BOLT



Specification
Sheet /

14

- G A substantial weldable Dropbolt designed for securing double gates
- G The ingenious design ensures that the Dropbolt cannot be lifted when both gates are closed
- G 19mm diameter dropbolt moves 100mm
- G Solid steel construction



PRODUCT CODE

ADB - Auto-locking drop bolt



INSTALLATION

Fix the lift plate to the Dropbolt with the screws provided – left hand or right hand as required.

Remove the galvanising from the weld area and weld the locating tube to the first gate to be closed at 16mm from the centre of the tube to the edge of the gate. Ensure that the horizontal slots are towards the edge of the gate.

Slide the Dropbolt into the tube and fix the lifting plates so that when the Dropbolt is rotated the lifting plate will fold flat against the edge of the gate.

Determine the required vertical position of the Dropbolt and drive the steel pin into one of the three holes provided.

Dropbolt diameter = 19mm

MAINTENANCE

Lubricate sliding parts periodically

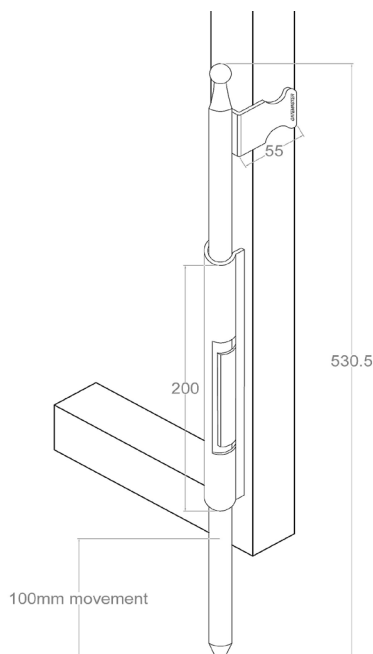

 **GATEMASTER**

VISIT SIGNETLOCKS.CO.UK FOR MORE
INFORMATION