

# GATEMASTER SELECT PRO WELD IN LONG THROW KEYLATCH



- G** Gate will lock shut and will require the key to open every time.
- G** Stainless steel latchbolt which springs a unique 22mm (7/8") into the gate post. Long throw for extra security.
- G** Supplied with bolt guide plate and gate post strike plate to ensure extra smooth closing action.
- G** Adjustable latchbolt for precise fitting. Easy to rotate for LH and RH gates.



## PRODUCT DETAILS

Product code:	Description:
SWKLLT1630	For 30mm (1-1/8") wide gate frames
SWKLLT1640	For 40mm (1-5/8") wide gate frames
SWKLLT1650	For 50mm (2") wide gate frames
SWKLLT1660	For 60mm (2-3/8") wide gate frames

Latchbolts: Adjustable, latchbolt springs 22mm (7/8").

Perfect for both left handed and right handed gates.

This weld-in lock can be galvanised or powder coated with the rest of the gate. Just remove the internal lock mechanism and weld the case in place before painting or powder coating.

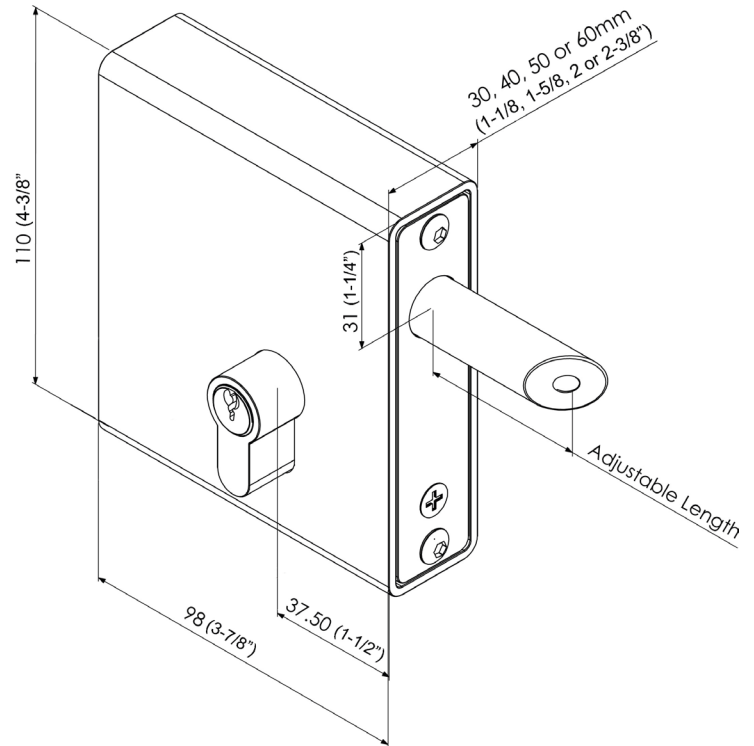

## INSTALLATION

1. Disassemble the lock by removing the 3 screws from the face plate of the lock, remove the face plate, and then remove the euro cylinder (twist the key 15 degrees clockwise or anti-clockwise to release). The insides of the lock will then slide out.
2. Weld the lockcase to the gate and galvanise or paint as part of the gate.
3. Fit the lock and eurocylinder into the lockcase and secure with screws.
4. **MAINTENANCE** Every two months, lubricate the latchbolt with light oil. Annually, dismantle lock and spray the mechanism inside with light oil.



## GATEMASTER

VISIT [GATEMASTERLOCKS.COM](http://GATEMASTERLOCKS.COM) FOR MORE INFORMATION