

DOUBLE THROW LATCH DEADLOCK FOR WELDING



SPECIFICATION SHEET

GLD

- Weldable lock with handle and a double throw deadbolt that moves 24mm into the gate post.
- Available in different widths to suit gate thickness
- Available in a Fire Brigade version - FB1 and FB2 key.
- No need to disassemble for left or right hand gates - simply remove lock from outer case, lift latch retaining spring, remove latch and reinstall as required.

PRODUCT DETAILS

Product code:	Description:
GLD30	30mm case width, mild steel case
GLD40	40mm case width, mild steel case
GLD50	50mm case width, mild steel case
GLD60	60mm case width, mild steel case

Material: Mild steel case.

Keyed alike option available.

Suitable for left and right handed gates.



INSTALLATION

- Weld the outer lockcase into the gate and galvanise or paint as part of the gate.
- Fit the lock into the lockcase and secure using 4 countersunk screws and the eurocylinder.
- Drill clearance hole in keep or outer frame to receive the latchbolt. Slot this hole vertically to allow for gate sag.
- Ensure latchbolt moves freely without binding on the gate or frame.
- MAINTENANCE** Annually remove the lock from the lockcase and lightly oil all moving parts.

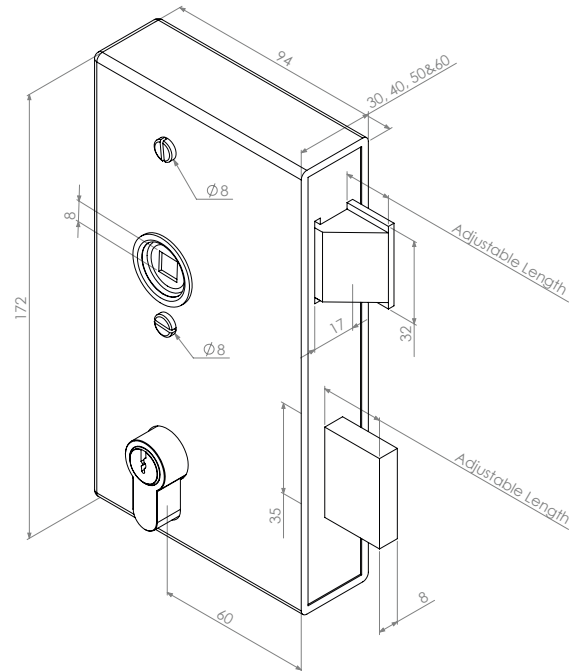

VISIT GATEMASTERLOCKS.COM FOR MORE INFORMATION