

# AUTOLOCKING DROPBOLT



Specification Sheet / 089

- G** A substantial weldable or screw fixed dropbolt designed for securing double gates.
- G** The ingenious design ensures that the dropbolt cannot be lifted when both gates are closed.

## PRODUCT DETAILS

Product code:	Description:
ADB	Autolocking dropbolt, weld on version
ADBS	Autolocking dropbolt, screw fixed version

Material                      Solid steel

Dropbolt diameter        19mm  
Dropbolt movement       100mm



## INSTALLATION WELD ON

1. Fix the lift plate to the dropbolt with screws provided - left hand or right hand as required.
2. Remove the galvanising from the weld area and weld the locating tube to the first gate to be closed at 15mm from the centre of the tube to the edge of the gate. Ensure that the horizontal slots are towards the edge of the gate.
3. Slide the dropbolt into the tube and fix the lifting plates so that when the dropbolt is rotated, the lifting plate will fold flat against the edge of the gate.
4. Determine the required vertical position of the dropbolt and drive the steel pin into one of the three holes provided.
5. **MAINTENANCE** Lubricate sliding parts periodically.

## INSTALLATION SCREW FIXED

1. Fix the lift plate to the dropbolt with screws provided - left hand or right hand as required.
2. Fix the locating tube to the gate with the fixings supplied. Ensure that the horizontal slots are towards the edge of the gate.
3. Slide the dropbolt into the tube and fix the lifting plates so that when the dropbolt is rotated, the lifting plate will fold flat against the edge of the gate.
4. Determine the required vertical position of the dropbolt and drive the steel pin into one of the three holes provided.
5. **MAINTENANCE** Lubricate sliding parts periodically.

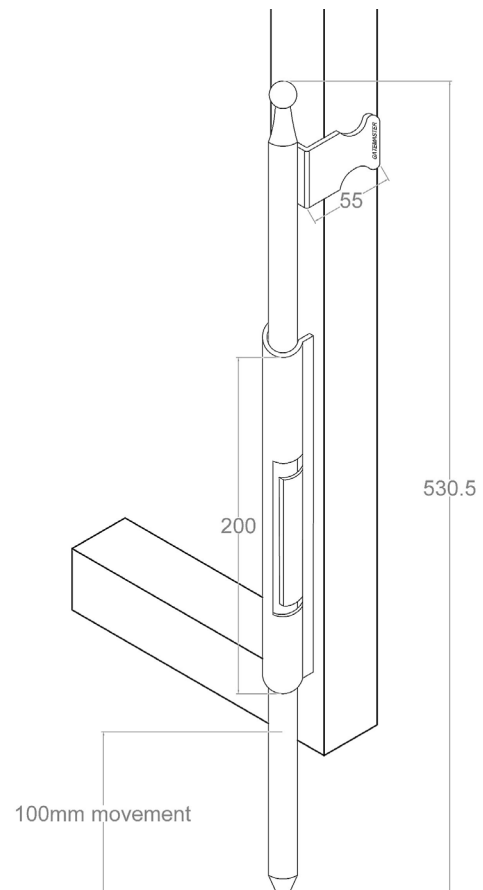

VISIT [SIGNETLOCKS.CO.UK](http://SIGNETLOCKS.CO.UK) FOR MORE INFORMATION

