

GATE MAGLOCK SYSTEM



SPECIFICATION SHEET

/ 069

- G** This kit includes a high quality, 545kg holding force stainless steel maglock and powder coated attachment plates with integral pull handles for opening the gate. Easy to fit with fixings provided.
- G** The maglock incorporates a switch which provides a locked/unlocked signal.
- G** The simplest way to fit a maglock to a gate.

PRODUCT DETAILS

Product code:	Description:
EMGK	Gate maglock system

Maglock size: 203 x 63mm
 Voltage/current: 12V/500mA, 24V/250mA
 Lock status switch rating: 250mA
 Material: Stainless steel.
 Holding force: 545kg

Includes: Powder coated attachment plates, pull handles, fixings.



WIRING INSTRUCTIONS

- For 12V, connect the red/black wires, green/orange wires and connect the 12V source.
- For 24V, connect the black/green wires, red/orange wires and connect to a 24V source.

12V	24V	Lock Status Sensor
+	+	
-	-	

INSTALLATION

1. **MAGLOCK ARMATURE** Drill three holes through the gate and bolt the maglock armature and the pull handles in place using the two coach bolts and the break off nuts provided.

The third hole is to provide clearance for the nut on the back of the armature plate.

2. **MAGLOCK** Close the gate and position the maglock assembly on the gate post, and fix with the M8 screws provided. Alternative fixing methods may be required depending on the type of gate post.

3. **HOW TO OPERATE** The maglock can be operated using a separate keypad, switch or proximity fob and is easily incorporated into any access control system. The gate is easily opened and closed using the pull handles included.

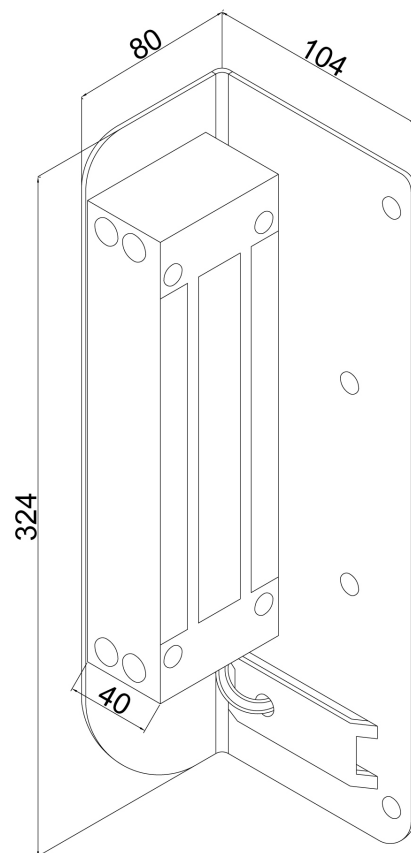

G GATEMASTER

VISIT SIGNETLOCKS.CO.UK FOR MORE INFORMATION

