

# STAINLESS STEEL GATE CLOSING STRUT



SPECIFICATION SHEET / 013

- Top quality gate closing strut, ideal for closing gates up to 80kg.
- Using the unique adjustable brackets the force this closer exerts can be altered as required.
- No need to release gas, simply move the strut along the slots in the brackets to adjust the force exerted. The force can be increased again by moving the strut further than the gate hinge.
- The adjustable brackets also make the installation easy as there is no need to compress the spring when fitting it to the gate.



## PRODUCT DETAILS

Product code:	Description:
GSS GSSW	Stainless steel gate closing strut, weld on Stainless steel gate closing strut, screw fixed

Max gate weight:	80kg
Max gate size:	2500mm high x 1200mm wide
End fittings:	M10 elbow joints Fitted with steel rod protection tube.
Finish:	Stainless steel
Center to center:	772mm
Stroke length:	250mm
Force:	300N

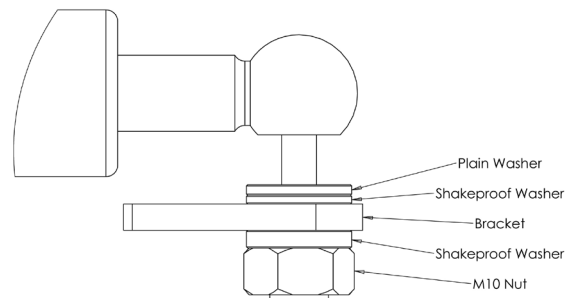

## INSTALLATION

- Weld or screw the brackets supplied in position relative to the center of the hinge as shown. **WARNING!** Do not weld the brackets with closer fitted, this could damage the seals.
- Close the gate and secure the strut to the slotted bracket and the long bracket using the shakeproof washers and nuts provided. Washers position are as shown - use spanner supplied to hold ball joint. To increase or decrease the force exerted on the gate, reposition the strut on the long bracket as required.
- MAINTENANCE** The piston rod is protected by a steel cover tube. The piston rod should not be lubricated or damaged in any way, as this will reduce the life of the seals. Periodically lubricate the ball joints with a light oil and clean the surface of the gas strut with a damp cloth.

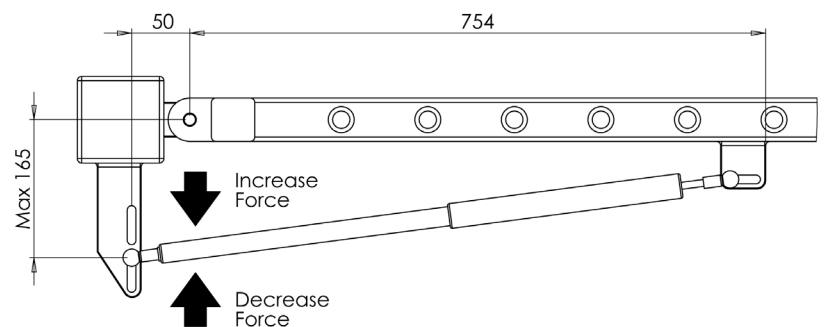

GATEMASTER

VISIT [SIGNETLOCKS.CO.UK](http://SIGNETLOCKS.CO.UK) FOR MORE INFORMATION

