

SPRING GATE CLOSER



SPECIFICATION
SHEET

SGC

- Ⓜ A helical door spring with pivoted arm. This closer will close gates up to 40kg.
- Ⓜ The arm locates between 2 rollers mounted on the door to eliminate wear on the door.
- Ⓜ The closing speed is adjusted by inserting the tension bar supplied and increasing or decreasing the tension as required.

PRODUCT DETAILS

Product code:	Description
SGC	Spring Gate Closer

Max gate weight 40kg

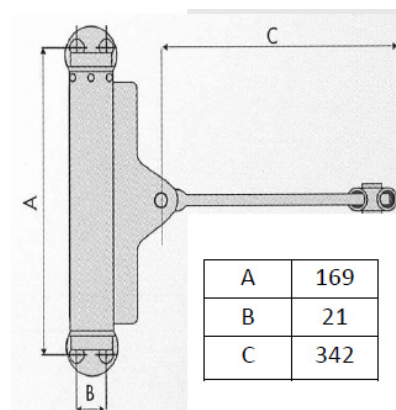

INSTALLATION

Screw fix spring to gate post and roller bracket to gate.

MAINTENANCE

Light oil periodically

 **GATEMASTER**

VISIT GATEMASTERLOCKS.COM FOR MORE
INFORMATION

